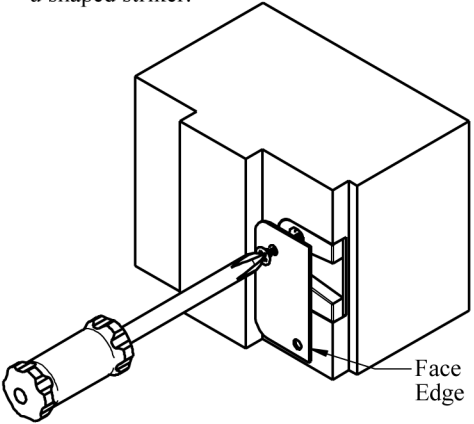
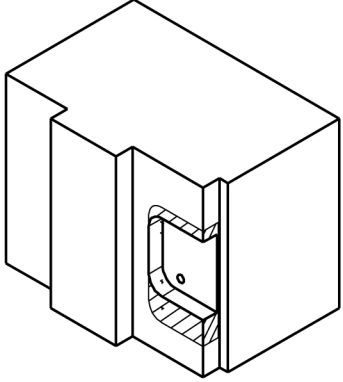
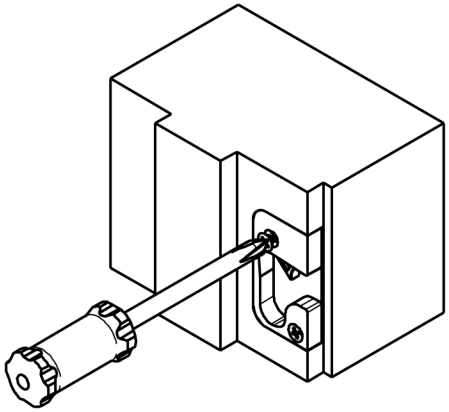

Replacing an Old Fuhr Multipoint System with a current HOPPE Automatic System

When replacing an old Fuhr Multipoint System with a current HOPPE automatic system, you must have the customer replace the automatic release bracket and the underplate in order for the new automatic system to work. Sometimes this creates a problem when the new system doesn't line up exactly to the old system. It may require the customer to notch out his door frame and in some cases, there is even an overlap from the old release bracket to the new one and this can mean a lot more rework. When this occurs, we can offer the customer the manual version as long as we explain that they will need to lift the handle to lock the system. They will not need to reposition the release bracket - they can just leave it in place but it won't be functional.

Installation of HLS Multipoint System Auto Release Strike (When Replacing Old Automatic Gear)

<p>① Remove top screw from existing u-shaped strike and attach new underplate directly on top of the existing u-shaped strike with the screw you removed. Line up face edge of new underplate with the edge of jamb (see below).</p> <p>Mark an outline of the underplate on the frame.</p> <p>Remove the screw to remove underplate, remove second screw from existing strike and take out old u-shaped striker.</p> 	<p>② Route inside the outline you made (shown below as the shaded area) to remove the excess frame material.</p> <p>Note: Increase the depth to 9.5mm [3/8"]</p> 
<p>③ Insert the new underplate and then the new auto release striker into frame and tighten screws.</p> <p>Install the new multipoint gear system as per instructions.</p> 	<p>④ Adjust the auto release pin. Loosen screw using a 3mm allen wrench to adjust the position of the auto release pin, then tighten to fix position.</p> 