



CUSTOM MADE PATIO SCREEN DOOR ORDER FORM

Account# _____ Salesman _____ Page# _____ of _____

Sold To: _____ Ship To: _____

Purchase Order# _____ Date _____ Quoted By _____

STEP 1 Determine style and material of door

- Custom Roll Form Aluminum
- Custom Roll Form Steel
- Multi-Fit Roll Form Aluminum
- Custom Extruded Aluminum

STEP 2 Determine finish

- Mill (Aluminum Doors) - Not Available for MOOSE
- Gray (Steel Doors)
- White
- Bronze
- Other _____

STEP 3 Select screen cloth or screen wire

- Charcoal Fiberglass (standard)
- Gray Fiberglass
- Bright Aluminum
- Charcoal Aluminum
- Other _____
- None (Apply's only to Riviera, Deluxe, Regal & Majestic Knocked Down Doors)

STEP 4 Select type of wheel

- Nylon
- Steel
- Stainless Steel

STEP 5 Determine head and sill rail depth

- (Note: Deep head/sill only available on assembled Apollo custom aluminum doors)
- 1/16" to 1/4" (standard)
 - 5/16" to 5/8"

STEP 6 Lock Assembly Location:

- Centered (Reversible)
- Inches _____

Measure from the top of the sill track bead up to the center of the existing keeper.

View from the Inside Looking Out: RH LH (check one)

STEP 7 Bug Seal:

- Vinyl Bug Flap - Select Size: 7/8" 1-1/8" 1-1/2"
 - Wool Pile - Select Size: .250" .350" .370** .380" .450" .500" .580** .600" .650" .750"
- *Used on Regal Door

STEP 8 Measuring Instructions for Custom Screens

Width: Measure from inside the jamb to the center of the first rail of the fixed door.

Height: See Illustration:

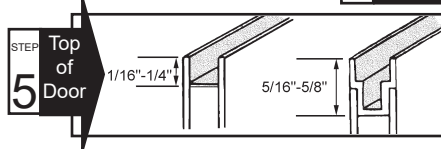
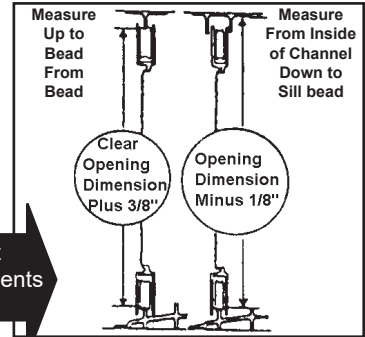

STEP 9 Select Part Number, Quantity & Size

- 991M-999 ENTERPRISE Custom Roll Form Steel - Assembled
- 997M-999 BOSS Heavy Duty Custom Roll Form Steel - Assembled
- 992M-999 APOLLO Custom Roll Form Aluminum - Assembled
- 995M-999 TITAN Classic Custom Extruded Aluminum - Assembled
- 998M-999 TITAN Contemporary Custom Extruded Aluminum - Assembled
- 996-999 MOOSE Custom Extruded Aluminum - Assembled
- 999M-999 GEMINI Custom Extruded Aluminum - Assembled
- 995F-999 DELUXE Custom Extruded Aluminum - Assembled
- 998F-999 REGAL Custom Extruded Aluminum - Assembled
- 996F-999 MAJESTIC Custom Extruded Aluminum - Assembled
- 999F-999 RIVIERA Custom Extruded Aluminum - Assembled
- 991M-999KD ENTERPRISE Custom Roll Form Steel - Knocked Down
- 997M-999KD BOSS Heavy Duty Custom Roll Form Steel - Knocked Down
- * 992M-999KD APOLLO Custom Roll Form Aluminum - Knocked Down
- 995M-999KD TITAN Classic Custom Extruded Aluminum - Knocked Down
- 998M-999KD TITAN Contemporary Custom Extruded Aluminum - Knocked Down
- 996-999KD MOOSE Custom Extruded Aluminum - Knocked Down
- 999M-999KD GEMINI Custom Extruded Aluminum - Knocked Down
- 995F-999KD DELUXE Custom Extruded Aluminum - Knocked Down
- 998F-999KD REGAL Custom Extruded Aluminum - Knocked Down
- 996F-999KD MAJESTIC Custom Extruded Aluminum - Knocked Down
- 999F-999KD RIVIERA Custom Extruded Aluminum - Knocked Down

*Note: Cloth and Spline are not included with Apollo Knocked Down Doors

Part#	Quantity	Size	Price Each	Amount
		_____ " width x _____ " height		
891-999-3		Less than 10 charge	\$ _____	
891-999-1		Less than 5 charge	\$ _____	
891-999-2		Top Hung System	\$ _____	
			TOTAL	
			FREIGHT	

To determine the correct "Top Hung" patio door height to fit your opening, go to: <http://www.strybuc.com/90M/Top-Hung-Patio-Door-fitting.pdf>

I understand that this material is not regular stock, but custom made to specifications as stated above. I understand and accept the condition that this material is NON RETURNABLE and NON-CANCELABLE. See Specific Series for Prepaid Freight Terms. IT IS THE RESPONSIBILITY OF THE CUSTOMER TO INSPECT FOR DAMAGE, AND MAKE THE CLAIM WITH THE CARRIER, AS WE ARE NOT RESPONSIBLE FOR DAMAGE.

***Please Note*: Carrier charges continue to fluctuate. Please call for delivery charges.**

Signature of Authorized Buyer _____ Buyer Phone _____

Title _____



DAMAGED WINDOW/PATIO DOOR SCREENS DELIVERY

TRUCK SHIPMENT:

You must check the boxes thoroughly BEFORE you sign and follow the procedures below.

If there is visible damage to the entire shipment, you should refuse it.

If there is partial damage, you should sign the BOL (Bill of Lading) as 1 of 5 boxes damaged, 2 of 5 boxes damaged, etc. Then notify us immediately and save the box and materials. We will start the claim process. Take pictures of the damaged box(s) and send that to us so we can submit with the claim paperwork.

If there is concealed damage and you signed for it "clear", it becomes more of a problem area. Notify us immediately. We can initiate the claim BUT there is a good chance it won't be approved. Take pictures of the screens damaged inside, and save the box and materials.

SMALL PARCEL (UPS & FEDEX):

Follow the same procedures as TRUCK SHIPMENT above.

If concealed damage, we will have the carrier do a "driver follow-up" to review the saved box and materials.

If it is left at the door unsigned and then you see damage(s) to it, you must notify us immediately. Save the box and materials. We will initiate the claim process by having the carrier do a "driver follow-up" to review the saved box and materials.